



## *Introducing Signature v.3* | Loaded with innovations and breakthroughs in technology!

The critically acclaimed Paradigm® Reference Signature speakers are the Paradigm designers' playground, an opportunity to explore any and all possible new design technologies without regard for time or cost. In this latest version, groundbreaking technology from literally hundreds of hours of research, design, and testing, has led to an amazing 50% increase in output (+3 dB)! Yes, Signature Series speakers are now the highest output, most dynamic high-end loudspeakers ever produced! Get ready to be bowled over by this truly breathtaking new generation.

Also new to this series, the Signature compact lifestyle models—S1, C1 and ADP1—offer a Paradigm Reference G-PAL™ (gold-plated pure-aluminum) dome tweeter option. This makes Signature quality more affordable for those anxious to jump into world of Paradigm Signature Series' ultimate high-end audio performance, but conscious of cost.



Double the power (+3 dB!) — an incredible achievement!

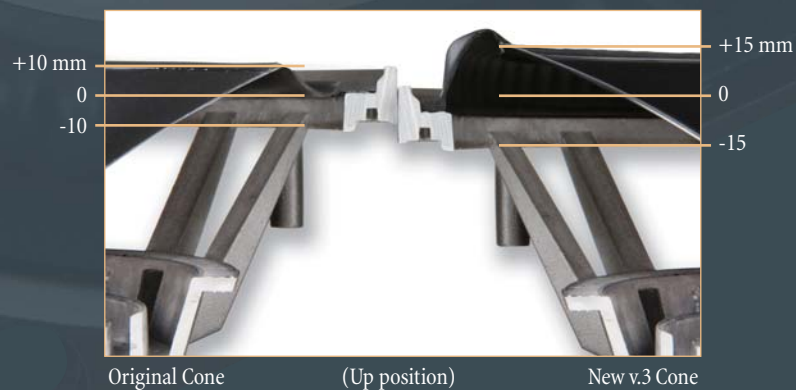
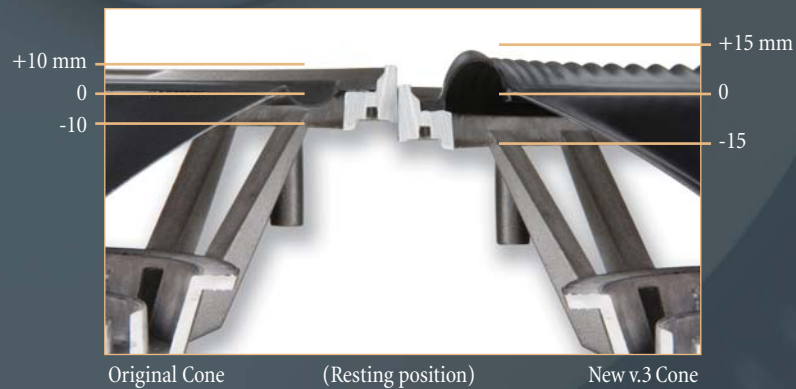
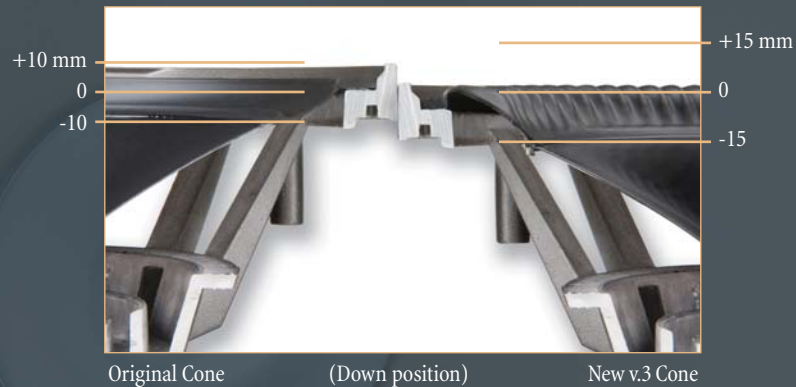

In designing the original Signature midrange and bass drivers our challenge was to generate supremely accurate and predictable response from these exceptionally high-output designs. This time our goal was simply more.

Bass/midrange drivers have been fitted with extreme low-density NLC™ Non-Limiting Corrugated TPE surrounds (see right), FEA-optimized and overmolded onto the cone here in house. The new state-of-the-art surround material is ten times more effective

than standard thermoplastic elastomers in damping vibrations and resonances and the new corrugated design has increased peak-to-peak excursion from 20-mm in earlier versions to a full 30-mm. And while the real story is the state-of-the-art surround material, not to be discounted is the new long-stroke split-coil motor system designed to take advantage of the extreme excursion. The motor doubles the linear portion of the stroke without the need for a larger magnet, keeping mass and inductance of the voice coil low (see below). The result? Supremely breathtaking midrange clarity, superior sensitivity and an incredible 50% increase in output (+3 dB!).

Bass cones were also extensively re-engineered. Injection-molded in house they benefit from a 30% mineral content—a much stiffer cone has evolved. New NLC™ Non-Limiting Corrugated Santoprene® surrounds, optimized using FEA and overmolded directly onto the cone, allow it to travel 50% farther (see photographs above). Dimpling and wrinkling? Even at peak excursion not a hint of distortion rears its ugly head. To support the extended excursion we also redesigned the motor structure, increasing the linear portion of the stroke through voice coils almost double the original in length. New core parts—yoke and pole piece—were retooled and FEA-optimized and even the magnets were thickened to accommodate double-distance cone travel. As in bass/midrange drivers we achieved a 50% increase in output (+3 dB!).

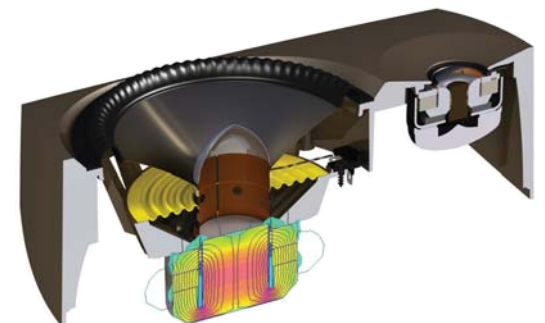

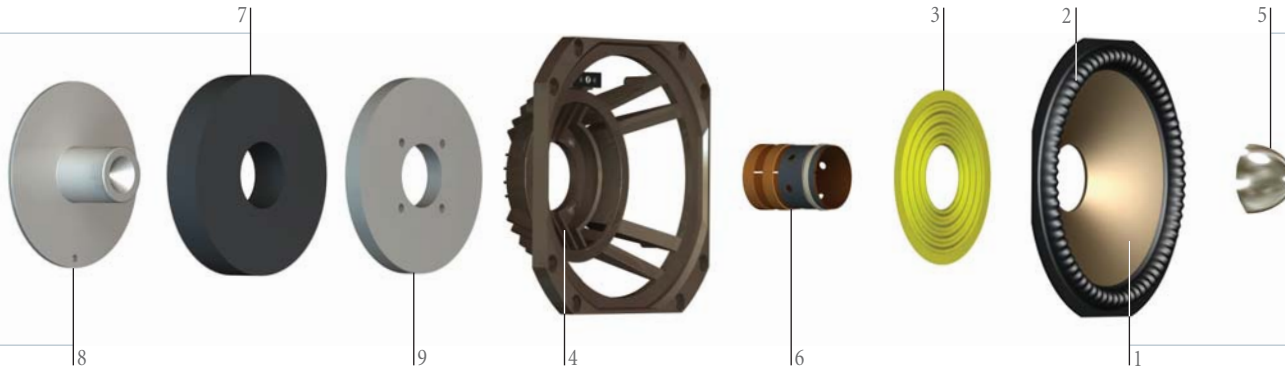

## The technology behind the redesigned Paradigm® Reference *Signature* v.3 Bass/Midrange Drive Units

### 1 | Co-PAL™ Cobalt-Infused Anodized Pure-Aluminum Bass/Midrange Cones:

Combine high stiffness-to-mass with superior internal damping for exceptional accuracy. The result is smooth, completely uncolored frequency response.

### 2 | NEW! Overmolded NLC™ Non-Limiting Corrugated TPE Surrounds:

The new cutting-edge TPE Thermoplastic Elastomer was chosen for its unmatched vibration and resonance damping properties, crucial to the optimal performance of a bass/midrange driver (full story on page 5).

### 3 | NEW! Advanced Nomex® Spiders:

Retooled for added depth to accommodate the increase in excursion ... the restorative force is now more accurate than ever.

### 4 | NEW! Redesigned Die-Cast Aluminum Heatsink Chassis with AVS™ Cooling:

Deeper than previous generations to accommodate the new driver technology, the die-cast chassis baskets maintain our trademark AVS™ Airflow Ventilation System cooling, boosting power handling, ensuring ultra-low distortion and exceptional reliability. CNC-machined to ensure a precision fit.

### 5 | NEW! Metallized High-Integrity Dust Caps:

Dust caps proved a better mate with the new driver technology, improving structural integrity and removing any opportunity for air noise to introduce distortion. Shaped to promote wide, uniform off-axis dispersion and smooth, extended frequency response.

### 6 | NEW! Cutting-Edge Long-Stroke Split-Coil Motor System:

Intermodulation distortion is virtually non-existent. Lightweight, high-temperature aluminum wire is wound on an Apical™ former (more on page 5).

### 7 | NEW! Permanent Ceramic (Hard Ferrite) Magnets with Focused-Field Geometry:

Rigid, high-temperature, low-mass design wound on ventilated Kapton® formers ensure superb accuracy and reliability.

### 8 | NEW! Retooled Magnetic Pole Piece:

FEA-optimized and retooled to support the 50% increase in cone excursion.

### 9 | NEW! Retooled Metal Top Plate:

FEA-optimized and retooled to support the 50% increase in cone excursion.

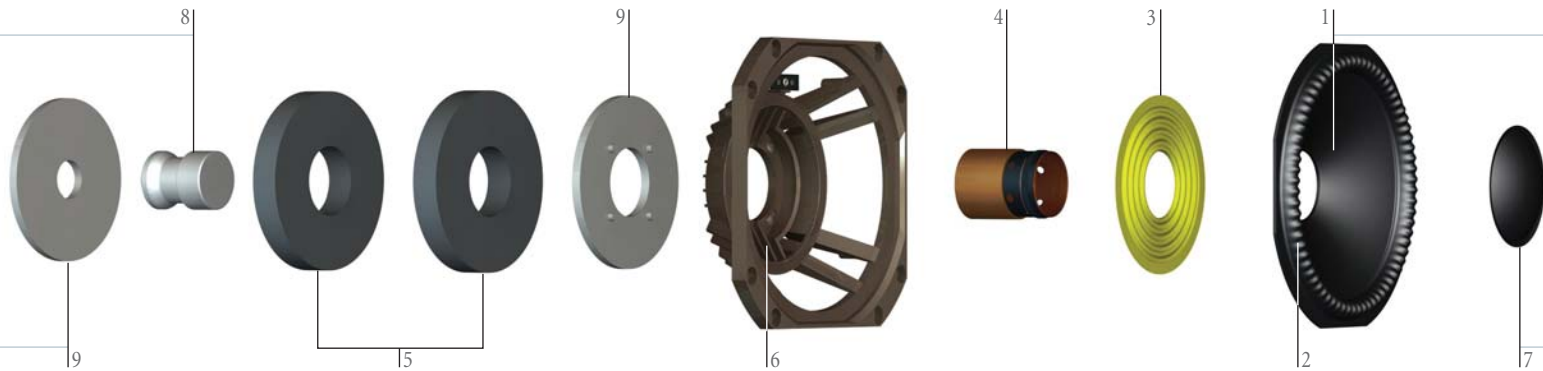

## The technology behind the redesigned Paradigm® Reference *Signature* v.3 Bass Drive Units

- 1 | **NEW! Injection-Molded Mineral-Filled Polypropylene Bass Cones:**  
The mineral content, now 30%, and the injection-molding process has resulted in a far more rigid cone. The improvements reveal a dramatic increase in repeatability as well as consistency of performance.
- 2 | **NEW! Overmolded NLC™ Non-Limiting Corrugated Santoprene® TPV Surrounds:**  
An advanced thermoplastic vulcanizate, Santoprene® was chosen for its extreme flexibility as well as durability in a variety of environmental conditions. Overmolded for superior lasting bond (full story on page 5).
- 3 | **NEW! Advanced Nomex® Spiders:**  
To take advantage of the higher excursion, spiders were retooled for added depth ... the restorative force is even more accurate.
- 4 | **NEW! Cutting-Edge Long-Stroke Low-Distortion Motor System:**  
The new design doubles the linear portion of the stroke to exploit the possibilities inherent in the extended excursion (full story on page 5). High-temperature aluminum wire is wound on an Kapton® former.
- 5 | **NEW! Massive Dual Permanent Ceramic (Hard Ferrite) Magnets with Focused-Field Geometry:**  
Break-through design and technology yield extremely high power output, remarkably low distortion and excellent power handling. Double the thickness of earlier versions to allow room for the 50% increase in cone excursion.
- 6 | **NEW! Redesigned Die-Cast Aluminum Heatsink Chassis with AVS™ Cooling:**  
Deeper than previous generations to accommodate the new driver technology, the die-cast chassis basket maintains our trademark AVS™ Airflow Ventilation System forced-air cooling to boost power handling, ensure ultra-low distortion and reliability. CNC-machined to ensure a precision fit.
- 7 | **High-Integrity Polypropylene Dust Caps:**  
Molded to promote wide, uniform off-axis dispersion as well as smooth, extended frequency response.
- 8 | **NEW! Retooled Magnetic Pole Piece:**  
FEA-optimized and retooled to support the 50% increase in cone excursion.
- 9 | **FEA-Optimized Metal Back and Top Plate:**  
Tooled to support the 50% increase in cone excursion.

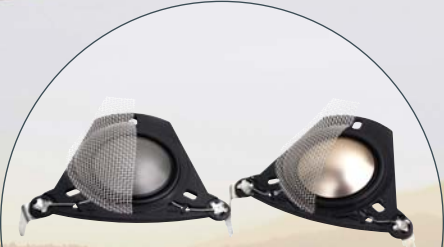

Compact lifestyle models, S1, C1 and ADP1 are also available with a G-PAL™ gold-plated pure-aluminum tweeter dome (above right). See Dealer for more information.





## Technical Specifications



**S1**

**Design**  
2-driver, 2-way, ultra-compact  
bookshelf / stand-mounted,  
shown on GS-30 stand



**S2**

**Design**  
2-driver, 2-way,  
bookshelf / stand-mounted,  
shown on J-29 stand



**S6**

**Design**  
4-driver, 3-way,  
floorstanding



**S8**

**Design**  
6-driver, 3-way,  
floorstanding

## S1 (G-PAL™)

### Crossover

3rd-order electro-acoustic at 2.1 kHz

### High-Frequency Driver

25-mm (1 in) G-PAL™ dome; ferro-fluid damped / cooled; rear damping chamber with ARB™ fins and integrated heatsink; dual super-neodymium ring magnets; die-cast enclosure / integrated heatsink chassis

### Bass / Midrange Driver

155-mm (6 in) Co-PAL™ cone; overmolded NLC™ surround; 38-mm (1-1/2 in) split voice coil; super-neodymium ring magnet; integrated AVS™ baffle / die-cast heatsink chassis

### Low-Frequency Extension\*

43 Hz (DIN)

### Frequency Response

#### On-Axis:

±2 dB from 65 Hz – 22 kHz

#### 30° Off-Axis:

±2 dB from 65 Hz – 18 kHz

### Sensitivity – Room / Anechoic

90 dB / 87 dB

### Suitable Amplifier Power Range

15 – 175 watts

### Maximum Input Power†

100 watts

### Impedance

Compatible with 8 ohms

### Height, Width, Depth

27.0 cm x 17.0 cm x 22.0 cm  
10-1/2 in x 6-3/4 in x 8-3/4 in

### Weight (unpacked)

5.8 kg / 12.5 lb each

### Finishes

Cherry, Natural Maple, Piano Black

### Matching Paradigm® Speaker Stand

GS-30

## S1 (P-Be™)

### Crossover

3rd-order electro-acoustic at 2.1 kHz

### High-Frequency Driver

25-mm (1 in) P-Be™ dome; ferro-fluid damped / cooled; rear damping chamber with ARB™ fins and integrated heatsink; dual super-neodymium ring magnets; die-cast enclosure / integrated heatsink chassis

### Bass / Midrange Driver

155-mm (6 in) Co-PAL™ cone; overmolded NLC™ surround; 38-mm (1-1/2 in) split voice coil; super-neodymium ring magnet; integrated AVS™ baffle / die-cast heatsink chassis

### Low-Frequency Extension\*

43 Hz (DIN)

### Frequency Response

#### On-Axis:

±2 dB from 65 Hz – 45 kHz

#### 30° Off-Axis:

±2 dB from 65 Hz – 20 kHz

### Sensitivity – Room / Anechoic

90 dB / 87 dB

### Suitable Amplifier Power Range

15 – 175 watts

### Maximum Input Power†

100 watts

### Impedance

Compatible with 8 ohms

### Height, Width, Depth

27.0 cm x 17.0 cm x 22.0 cm  
10-1/2 in x 6-3/4 in x 8-3/4 in

### Weight (unpacked)

5.8 kg / 12.5 lb each

### Finishes

Cherry, Natural Maple, Piano Black

### Matching Paradigm® Speaker Stand

GS-30

## S2

### Crossover

3rd-order electro-acoustic at 1.8 kHz

### High-Frequency Driver

25-mm (1 in) P-Be™ dome; ferro-fluid damped / cooled; rear damping chamber with ARB™ fins and integrated heatsink; dual super-neodymium ring magnets; die-cast heatsink chassis; IMS/SHOCK-MOUNT™\*

### Bass / Midrange Driver

178-mm (7 in) Co-PAL™ cone; overmolded NLC™ surround; 38-mm (1-1/2 in) split voice coil; hard ferrite magnet; AVS™ die-cast heatsink chassis; IMS/SHOCK-MOUNT™

### Low-Frequency Extension\*

36 Hz (DIN)

### Frequency Response

#### On-Axis:

±2 dB from 52 Hz – 45 kHz

#### 30° Off-Axis:

±2 dB from 52 Hz – 20 kHz

### Sensitivity – Room / Anechoic

91 dB / 88 dB

### Suitable Amplifier Power Range

15 – 225 watts

### Maximum Input Power†

140 watts

### Impedance

Compatible with 8 ohms

### Height, Width, Depth

38.1 cm x 21.0 cm x 35.6 cm  
15 in x 8-1/4 in x 14 in

### Weight (unpacked)

12.7 kg / 28 lb each

### Finishes

Cherry, Natural Maple, Piano Black

### Matching Paradigm® Speaker Stand

J-29

## S6

### Crossovers

3rd-order electro-acoustic at 2.0 kHz;  
2nd-order electro-acoustic at 190 Hz  
(bass drivers)

### High-Frequency Driver

25-mm (1 in) P-Be™ dome; ferro-fluid damped / cooled; rear damping chamber with ARB™ fins and integrated heatsink; dual super-neodymium ring magnets; die-cast heatsink chassis; IMS/SHOCK-MOUNT™

### Midrange Driver

178-mm (7 in) Co-PAL™ cone; ferro-fluid damped / cooled; ATC™ chambers; 38-mm (1-1/2 in) dual-layer voice coil; dual super-neodymium ring magnets; AVS™ die-cast heatsink chassis; IMS/SHOCK-MOUNT™

### Bass Drivers

Two 178-mm (7 in) mineral-filled polypropylene cones; overmolded NLC™ surrounds; 38-mm (1-1/2 in) four-layer bi-filar long-excursion voice coils; massive hard ferrite magnets; AVS™ die-cast heatsink chassis; IMS/SHOCK-MOUNT™

### Low-Frequency Extension\*

26 Hz (DIN)

### Frequency Response

#### On-Axis:

±2 dB from 45 Hz – 45 kHz

#### 30° Off-Axis:

±2 dB from 45 Hz – 20 kHz

### Sensitivity – Room / Anechoic

91 dB / 88 dB

### Suitable Amplifier Power Range

15 – 400 watts

### Maximum Input Power†

200 watts

### Impedance

Compatible with 8 ohms

### Height, Width, Depth

111.0 cm x 21.0 cm x 34.5 cm  
43-3/4 in x 8-1/4 in x 13-1/2 in

### Weight (unpacked)

31.8 kg / 70 lb each

### Finishes

Cherry, Natural Maple, Piano Black

## S8

### Crossovers

3rd-order electro-acoustic at 2.0 kHz;  
2nd-order electro-acoustic at 230 Hz  
(bass drivers)

### High-Frequency Driver

25-mm (1 in) P-Be™ dome; ferro-fluid damped / cooled; rear damping chamber with ARB™ fins and integrated heatsink; dual super-neodymium ring magnets; die-cast heatsink chassis; IMS/SHOCK-MOUNT™

### Midrange Driver

178-mm (7 in) Co-PAL™ cone; ferro-fluid damped / cooled; ATC™ chambers; 38-mm (1-1/2 in) dual-layer voice coil; dual super-neodymium ring magnets; AVS™ die-cast heatsink chassis; IMS/SHOCK-MOUNT™

### Bass Drivers

Two 178-mm (7 in) mineral-filled polypropylene cones; overmolded NLC™ surrounds; 38-mm (1-1/2 in) four-layer long-excursion voice coils; massive hard ferrite magnets; AVS™ die-cast heatsink chassis; IMS/SHOCK-MOUNT™

### Low-Frequency Extension\*

24 Hz (DIN)

### Frequency Response

#### On-Axis:

±2 dB from 39 Hz – 45 kHz

#### 30° Off-Axis:

±2 dB from 39 Hz – 20 kHz

### Sensitivity – Room / Anechoic

92 dB / 89 dB

### Suitable Amplifier Power Range

15 – 500 watts

### Maximum Input Power†

250 watts

### Impedance

Compatible with 8 ohms

### Height, Width, Depth

123.2 cm x 21.0 cm x 52.1 cm  
48-1/2 in x 8-1/2 in x 20-1/2 in

### Weight (unpacked)

45.3 kg / 100 lb each

### Finishes

Cherry, Natural Maple, Piano Black



*C1*

**Design**  
4-driver, 3-way, ultra-compact center channel



*C3*

**Design**  
4-driver, 3-way, center channel



*C5*

**Design**  
6-driver, 3-1/2-way, center channel

## C1 (G-PAL™)

### Crossovers

3rd-order electro-acoustic at 2.3 kHz;  
2nd-order electro-acoustic at 550 Hz  
(bass drivers)

### High-Frequency Driver

25-mm (1 in) G-PAL™ dome; ferro-fluid damped / cooled; rear damping chamber with ARB™ fins and integrated heatsink; dual super-neodymium ring magnets; die-cast enclosure / integrated heatsink chassis

### Midrange Driver

85-mm (3-1/2 in) Co-PAL™ cone; ferro-fluid damped / cooled; ATC™ chambers; 25-mm (1 in) dual-layer voice coil; dual super-neodymium ring magnets; AVS™ die-cast heatsink chassis

### Bass Drivers

Two 127-mm (5 in) mineral-filled polypropylene cones; overmolded NLC™ surrounds; 38-mm (1-1/2 in) two-layer split voice coils; super-neodymium ring magnets; AVS™ die-cast heatsink chassis

### Low-Frequency Extension\*

58 Hz (DIN)

### Frequency Response

#### On-Axis:

±2 dB from 73 Hz – 22 kHz

#### 30° Off-Axis:

±2 dB from 73 Hz – 18 kHz

### Sensitivity – Room / Anechoic

88 dB / 85 dB

### Suitable Amplifier Power Range

15 – 225 watts

### Maximum Input Power†

140 watts

### Impedance

Compatible with 8 ohms

### Height, Width, Depth

18.0 cm x 43.0 cm x 22.5 cm  
7 in x 17 in x 9 in

### Weight (unpacked)

10.5 kg / 25 lb each

### Finishes

Cherry, Natural Maple, Piano Black

### Matching Paradigm® Speaker Stand

n/a

## C1 (P-Be™)

### Crossovers

3rd-order electro-acoustic at 2.3 kHz;  
2nd-order electro-acoustic at 550 Hz  
(bass drivers)

### High-Frequency Driver

25-mm (1 in) P-Be™ dome; ferro-fluid damped / cooled; rear damping chamber with ARB™ fins and integrated heatsink; dual super-neodymium ring magnets; die-cast enclosure / integrated heatsink chassis

### Midrange Driver

85-mm (3-1/2 in) Co-PAL™ cone; ferro-fluid damped / cooled; ATC™ chambers; 25-mm (1 in) dual-layer voice coil; dual super-neodymium ring magnets; AVS™ die-cast heatsink chassis

### Bass Drivers

Two 127-mm (5 in) mineral-filled polypropylene cones; overmolded NLC™ surrounds; 38-mm (1-1/2 in) two-layer split voice coils; super-neodymium ring magnets; AVS™ die-cast heatsink chassis

### Low-Frequency Extension\*

58 Hz (DIN)

### Frequency Response

#### On-Axis:

±2 dB from 73 Hz – 35 kHz

#### 30° Off-Axis:

±2 dB from 73 Hz – 20 kHz

### Sensitivity – Room / Anechoic

88 dB / 85 dB

### Suitable Amplifier Power Range

15 – 225 watts

### Maximum Input Power†

140 watts

### Impedance

Compatible with 8 ohms

### Height, Width, Depth

18.0 cm x 43.0 cm x 22.5 cm  
7 in x 17 in x 9 in

### Weight (unpacked)

10.5 kg / 25 lb each

### Finishes

Cherry, Natural Maple, Piano Black

### Matching Paradigm® Speaker Stand

n/a

## C3

### Crossovers

3rd-order electro-acoustic at 1.8 kHz;  
2nd-order electro-acoustic at 370 Hz  
(bass drivers)

### High-Frequency Driver

25-mm (1 in) P-Be™ dome; ferro-fluid damped / cooled; rear damping chamber with ARB™ fins and integrated heatsink; dual super-neodymium ring magnets; die-cast heatsink chassis; IMS/SHOCK-MOUNT™

### Midrange Driver

102-mm (4 in) Co-PAL™ cone; ferro-fluid damped / cooled; ATC™ chambers; 25-mm (1 in) dual-layer voice coil; dual super-neodymium ring magnets; AVS™ die-cast heatsink chassis; IMS/SHOCK-MOUNT™

### Bass Drivers

Two 178-mm (7 in) mineral-filled polypropylene cones; overmolded NLC™ surrounds; 38-mm (1-1/2 in) four-layer voice coils; massive hard ferrite magnets; AVS™ die-cast heatsink chassis; IMS/SHOCK-MOUNT™

### Low-Frequency Extension\*

30 Hz (DIN)

### Frequency Response

#### On-Axis:

±2 dB from 46 Hz – 35 kHz

#### 30° Off-Axis:

±2 dB from 46 Hz – 20 kHz

### Sensitivity – Room / Anechoic

91 dB / 88 dB

### Suitable Amplifier Power Range

15 – 325 watts

### Maximum Input Power†

180 watts

### Impedance

Compatible with 8 ohms

### Height, Width, Depth

24.1 cm x 67.3 cm x 33.0 cm  
9-1/2 in x 26-1/2 in x 13 in

### Weight (unpacked)

20.4 kg / 45 lb each

### Finishes

Cherry, Natural Maple, Piano Black

### Matching Paradigm® Speaker Stand (sold sep.)

J-18C

## C5

### Crossovers

3rd-order electro-acoustic at 2.1 kHz;  
2nd-order electro-acoustic at 600 Hz;  
2nd-order electro-acoustic at 350 Hz  
(outer bass drivers)

### High-Frequency Driver

25-mm (1 in) P-Be™ dome; ferro-fluid damped / cooled; rear damping chamber with ARB™ fins and integrated heatsink; dual super-neodymium ring magnets; die-cast heatsink chassis; IMS/SHOCK-MOUNT™

### Midrange Driver

102-mm (4 in) Co-PAL™ cone; ferro-fluid damped / cooled; ATC™ chambers; 25-mm (1 in) dual-layer voice coil; dual super-neodymium ring magnets; AVS™ die-cast heatsink chassis; IMS/SHOCK-MOUNT™

### Bass / Midrange Drivers

Two 178-mm (7 in) Co-PAL™ cones; overmolded NLC™ surrounds; 38-mm (1-1/2 in) dual-layer long-excursion voice coils; massive hard ferrite magnet; AVS™ die-cast heatsink chassis; IMS/SHOCK-MOUNT™

### Bass Drivers

Two 178-mm (7 in) mineral-filled polypropylene cones; overmolded NLC™ surrounds; 38-mm (1-1/2 in) dual-layer long-excursion voice coils; massive hard ferrite magnets; AVS™ die-cast heatsink chassis; IMS/SHOCK-MOUNT™

### Low-Frequency Extension\*

24 Hz (DIN)

### Frequency Response

#### On-Axis:

±2 dB from 43 Hz – 35 kHz

#### 30° Off-Axis:

±2 dB from 43 Hz – 20 kHz

### Sensitivity – Room / Anechoic

93 dB / 90 dB

### Suitable Amplifier Power Range

15 – 500 watts

### Maximum Input Power†

250 watts

### Impedance

Compatible with 8 ohms

### Height, Width, Depth

24.1 cm x 95.3 cm x 44.4 cm  
9-1/2 in x 37-1/2 in x 17-1/2 in

### Weight (unpacked)

36.7 kg / 81 lb each

### Finishes

Cherry, Natural Maple, Piano Black

### Matching Paradigm® Speaker Stand (sold sep.)

J-18C



## ADP1

### Design

5-driver, 3-way, ultra-compact surround / rear on-wall



## ADP3

### Design

5-driver, 3-way, surround / rear

## ADP1 (G-PAL™)

### Crossovers

3rd-order electro-acoustic at 2.0 kHz;  
2nd-order electro-acoustic at 300 Hz

### High-Frequency Drivers

Two 25-mm (1 in) G-PAL™ domes; ferro-fluid damped / cooled; rear damping chambers with ARB™ fins and integrated heatsinks; dual super-neodymium ring magnets; die-cast heatsink chassis; IMS/SHOCK-MOUNT™

### Midrange Drivers

Two 85-mm (3-1/2 in) Co-PAL™ cones; ferro-fluid damped / cooled; ATC™ chambers; 25-mm (1 in) dual-layer voice coils; super-neodymium ring magnets; AVS™ die-cast heatsink chassis; IMS/SHOCK-MOUNT™

### Bass Driver

155-mm (6 in) mineral-filled polypropylene cone; overmolded NLC™ surrounds; 38-mm (1-1/2 in) dual-layer long-excursion voice coil; massive hard ferrite magnets; integrated AVS™ baffle / die-cast heatsink chassis; IMS/SHOCK-MOUNT™

### Low-Frequency Extension\*

60 Hz (DIN)

### Frequency Response

±2 dB from 100 Hz – 22 kHz  
(optimized reverberant soundfield)

### Sensitivity – Room / Anechoic

88 dB / 85 dB

### Suitable Amplifier Power Range

15 – 225 watts

### Maximum Input Power†

140 watts

### Impedance

Compatible with 8 ohms

### Height, Width, Depth

19.0 cm x 30.5 cm x 15.5 cm  
7-1/2 in x 12 in x 6 in

### Weight (unpacked)

7.0 kg / 15.5 lb each

### Finishes

Cherry, Natural Maple, Piano Black

### Matching Paradigm® Speaker Stand (sold sep.)

GS-30

## ADP1 (P-Be™)

### Crossovers

3rd-order electro-acoustic at 2.0 kHz;  
2nd-order electro-acoustic at 300 Hz

### High-Frequency Drivers

Two 25-mm (1 in) P-Be™ domes; ferro-fluid damped / cooled; rear damping chambers with ARB™ fins and integrated heatsinks; dual super-neodymium ring magnets; die-cast heatsink chassis; IMS/SHOCK-MOUNT™

### Midrange Drivers

Two 85-mm (3-1/2 in) Co-PAL™ cones; ferro-fluid damped / cooled; ATC™ chambers; 25-mm (1 in) dual-layer voice coils; super-neodymium ring magnets; AVS™ die-cast heatsink chassis; IMS/SHOCK-MOUNT™

### Bass Driver

155-mm (6 in) mineral-filled polypropylene cone; overmolded NLC™ surrounds; 38-mm (1-1/2 in) dual-layer long-excursion voice coil; massive hard ferrite magnets; integrated AVS™ baffle / die-cast heatsink chassis; IMS/SHOCK-MOUNT™

### Low-Frequency Extension\*

60 Hz (DIN)

### Frequency Response

±2 dB from 100 Hz – 45 kHz  
(optimized reverberant soundfield)

### Sensitivity – Room / Anechoic

88 dB / 85 dB

### Suitable Amplifier Power Range

15 – 225 watts

### Maximum Input Power†

140 watts

### Impedance

Compatible with 8 ohms

### Height, Width, Depth

19.0 cm x 30.5 cm x 15.5 cm  
7-1/2 in x 12 in x 6 in

### Weight (unpacked)

7.0 kg / 15.5 lb each

### Finishes

Cherry, Natural Maple, Piano Black

### Matching Paradigm® Speaker Stand (sold sep.)

GS-30

## ADP3

### Crossovers

3rd-order electro-acoustic at 1.8 kHz;  
2nd-order electro-acoustic at 260 Hz

### High-Frequency Drivers

Two 25-mm (1 in) P-Be™ domes; ferro-fluid damped / cooled; rear damping chambers with ARB™ fins and integrated heatsink; dual super-neodymium ring magnets; die-cast heatsink chassis; IMS/SHOCK-MOUNT™

### Midrange Drivers

Two 102-mm (4 in) Co-PAL™ cones; ferro-fluid damped / cooled; ATC™ chambers; 25-mm (1 in) dual-layer voice coils; super-neodymium ring magnets; AVS™ die-cast heatsink chassis; IMS/SHOCK-MOUNT™

### Bass Driver

210-mm (8 in) mineral-filled polypropylene cone; overmolded NLC™ surrounds; 38-mm (1-1/2 in) dual-layer long-excursion voice coil; massive ceramic / ferrite magnets; AVS™ die-cast heatsink chassis; IMS/SHOCK-MOUNT™

### Low-Frequency Extension\*

55 Hz (DIN)

### Frequency Response

±2 dB from 82 Hz – 45 kHz  
(optimized reverberant soundfield)

### Sensitivity – Room / Anechoic

89 dB / 86 dB

### Suitable Amplifier Power Range

15 – 250 watts

### Maximum Input Power†

180 watts

### Impedance

Compatible with 8 ohms

### Height, Width, Depth

33.7 cm x 35.9 cm x 19.1 cm  
13-1/4 in x 14-1/8 in x 7-1/2 in

### Weight (unpacked)

16.8 kg / 26 lb each

### Finishes

Cherry, Natural Maple, Piano Black

### Matching Paradigm® Speaker Stand (sold sep.)

J-29